

◆ M12 A-Coding 4A 4&5P Panel Rear Mount Female Solder

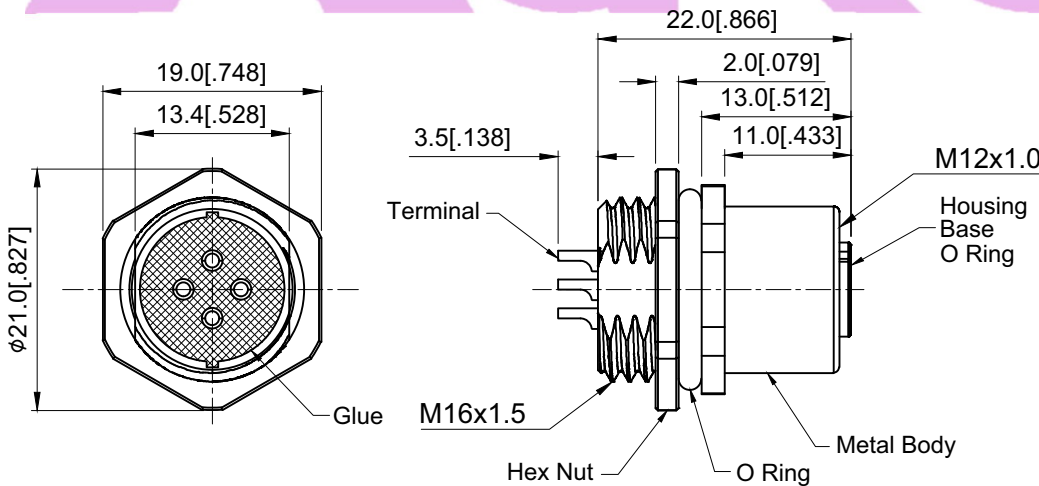
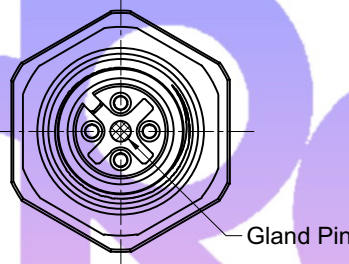
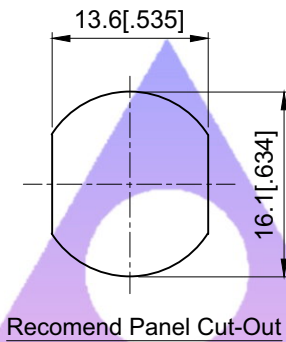

**Ordering Information:**  
CIR03 - A4 - \* C2 \* 000  
1 2

- 1.Pin Assignment  
4,5
- 2.Plating Options  
0:Gold Flash in Contact Area  
2:15u" Gold in Contact Area  
3:30u" Gold in Contact Area  
4:6u" Gold in Contact Area

**Physical:**

- ◆ Housing  
Thermoplastic, Black Color
- ◆ Terminal  
Copper Alloy
- ◆ Glue  
Epoxy, Black Color
- ◆ Gland Pin  
Thermoplastic, Black Color
- ◆ Base  
Thermoplastic, Black Color
- ◆ Metal Body  
Copper Alloy
- ◆ Hex Nut  
Copper Alloy
- ◆ O-Ring  
Silicone , Red & Black Color
- ◆ Terminal Plating  
Gold Plating
- ◆ Hex Plating  
Nickel Plating
- ◆ Metal Body  
Nickel Plating

**Specifications:**

- ◆ Waterproof Rate  
IP68
- ◆ Recommend Panel Thickness  
0.8mm to 3.0mm
- ◆ Recommend Torque  
6~7 kgf-cm
- ◆ Durability  
100 Cycles Min.
- ◆ DWV  
1400 Vrms for 4P  
1000 Vrms for 5P
- ◆ Rated Voltage  
250V AC/DC for 4P  
60V AC/DC for 5P
- ◆ Insulation Resistance  
100 MΩ Min.

Pin Assignment		
Model No.	CIR03-A4-4C2*000	CIR03-A4-5C2*000